

Back-to-back free-standing cascade configuration - 150 kW

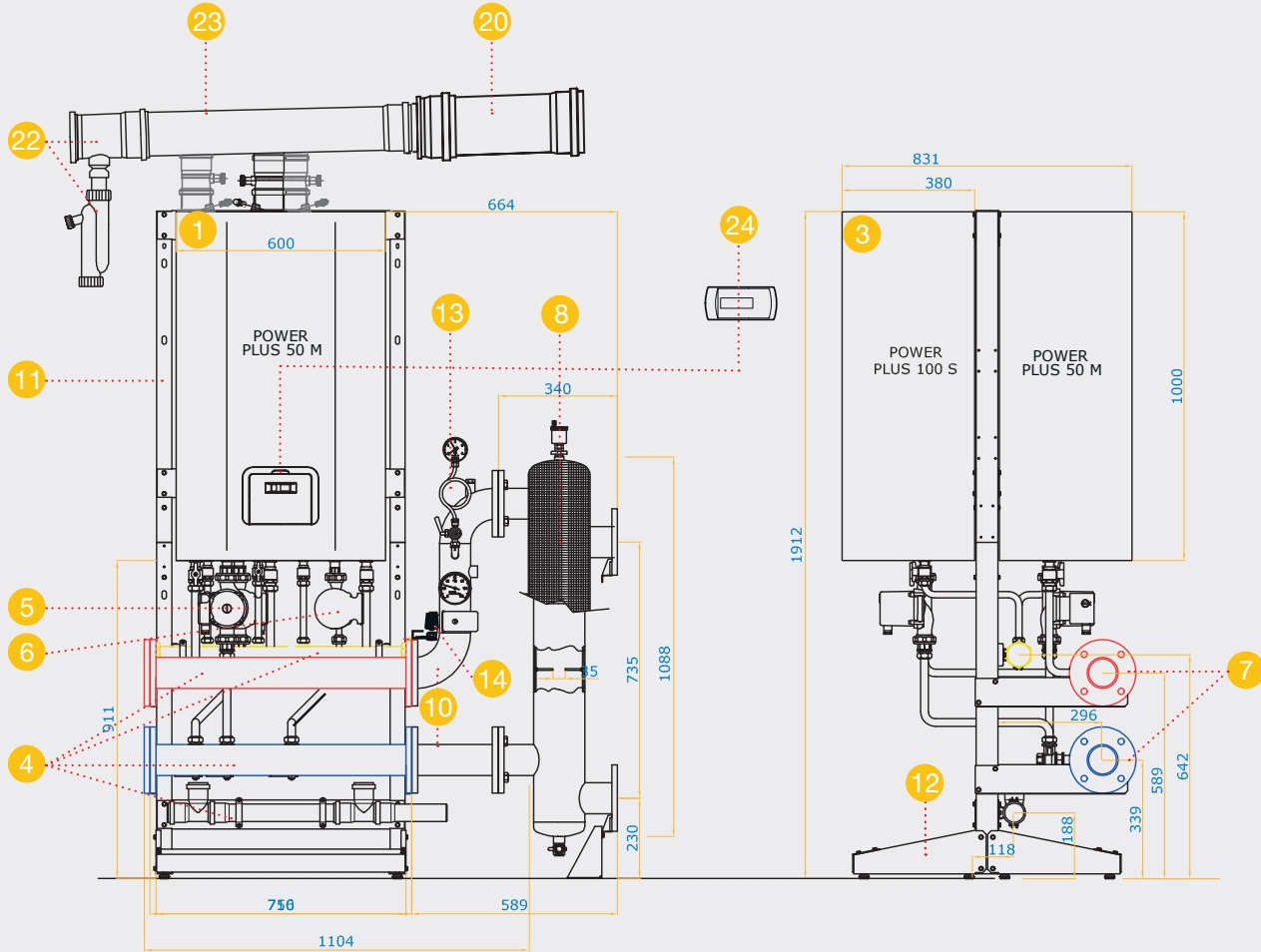

This scheme has only an indication purpose

| diagram ref. | code | description | quantity |
|---|-----------|--|----------|
| BOILERS | | | |
| 1 | 20019155 | Power Plus 50 M | 1 |
| 3 | 20019309 | Power Plus 100 S | 1 |
| USER INTERFACE | | | |
| 24 | 1102379* | Remote control | 1 |
| HYDRAULIC COMPONENTS and SAFETY DEVICES | | | |
| 4 | 20009439 | Hydraulic manifold kit up to 400 kW for Power Plus rig | 1 |
| 7 | 20009444 | Blank end-flange kit for hydraulic manifold | 1 |
| 5 | 20009442 | Pump kit (front) for Power Plus rig | 1 |
| 6 | 20009443 | Pump kit (rear) for Power Plus rig | 2 |
| 8 | 20009466 | Hydraulic header/separator - 150-200 kW | 1 |
| 10 | 20009471 | ISPESL hydraulic manifold | 1 |
| 13 | 20009475* | ISPESL safety kit (400 kW max.) | 1 |
| 14 | 20009482* | Gas safety cut-off valve (200 kW max.) | 1 |
| SUPPORTS for BACK-TO-BACK FREE-STANDING MOUNTING | | | |
| 11 | 20009472 | Power Plus rig (front mounting) | 1 |
| 12 | 20009474 | Rear mounting kit for Power Plus free-standing rig | 1 |

| diagram ref. | code | description | quantity |
|--------------|----------|---|----------|
| FLUES | | | |
| 23 | 4030311 | Flues collector kit Ø 125 for 50 kW | 1 |
| 21 | 4030312 | Flues collector kit Ø 125 for 100 kW | 1 |
| 20 | 20017306 | Flues collector kit for frontal/rear installation | 1 |
| 22 | 4030031 | Condensate drain kit Ø 125 whit tap | 2 |

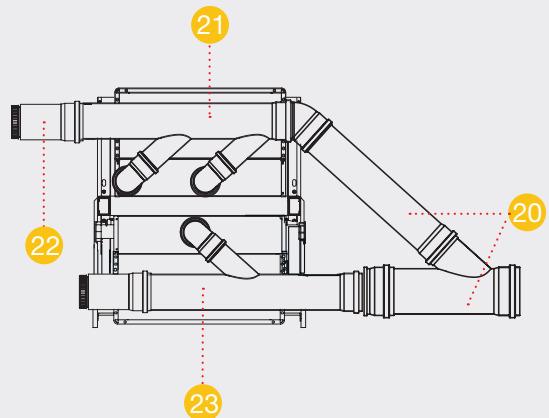

* OPTIONAL component